

품번	품명	수량
1	WEAR SLEEVE	1
2	BACKHEAD	1
3	CHECK VALVE with SPRING BUSH	1
4	CHECK VALVE BOX	1
5	AIR TUBE PIN	1
6	AIR TUBE	1
7	PLUG-BLIND	1
8	PISTON	1
9	GUIDE BUSH	1
10	BIT RETAINING RING & O-RING	1
11	CHUCK	1
12	BIT	1

		CHANG-SHIN INT'L CO.,LTD ULSAN KOREA	
		TITLE Speedrill 40IR Hammer Assy	
APP'D		MATERIAL	
CH'D		MODEL	
CH'D		STANDARD	
DRAW		Proj: 3각법	DWG NO. CS-SP40IR-00
DATE	SIGN.	Weight 47.3 kg	

REV.	DESCRIPTION	DATE	DWG	CH'D	CH'D	APP'D
△	First Issued	'16.11.15	J.Y.CHO	CH.R.KIM	-	C.G.LEE

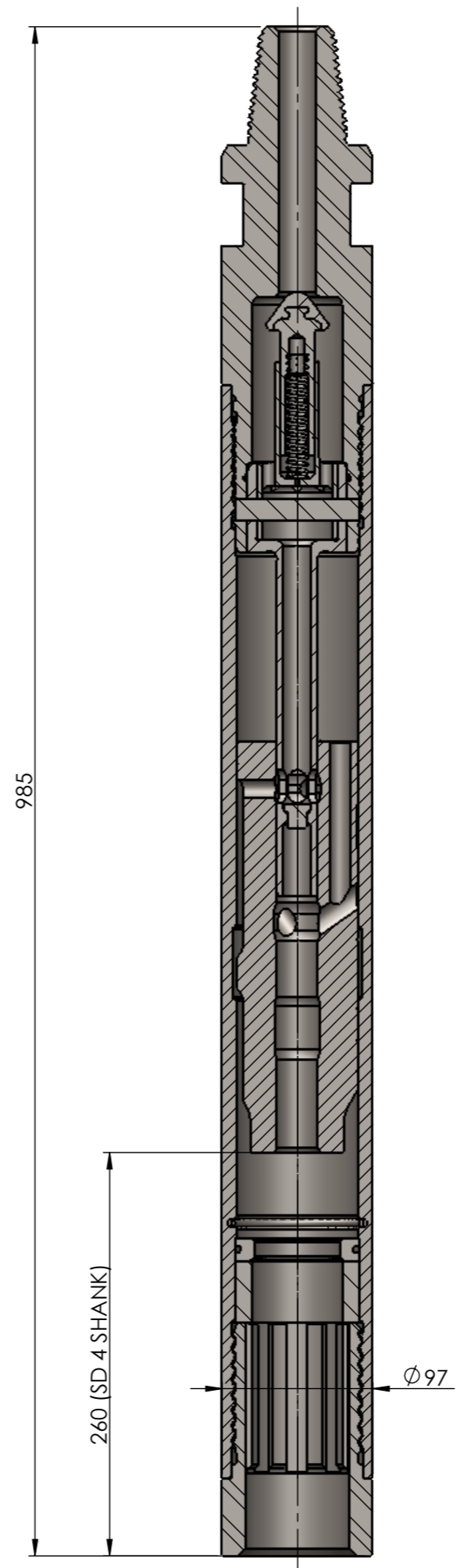
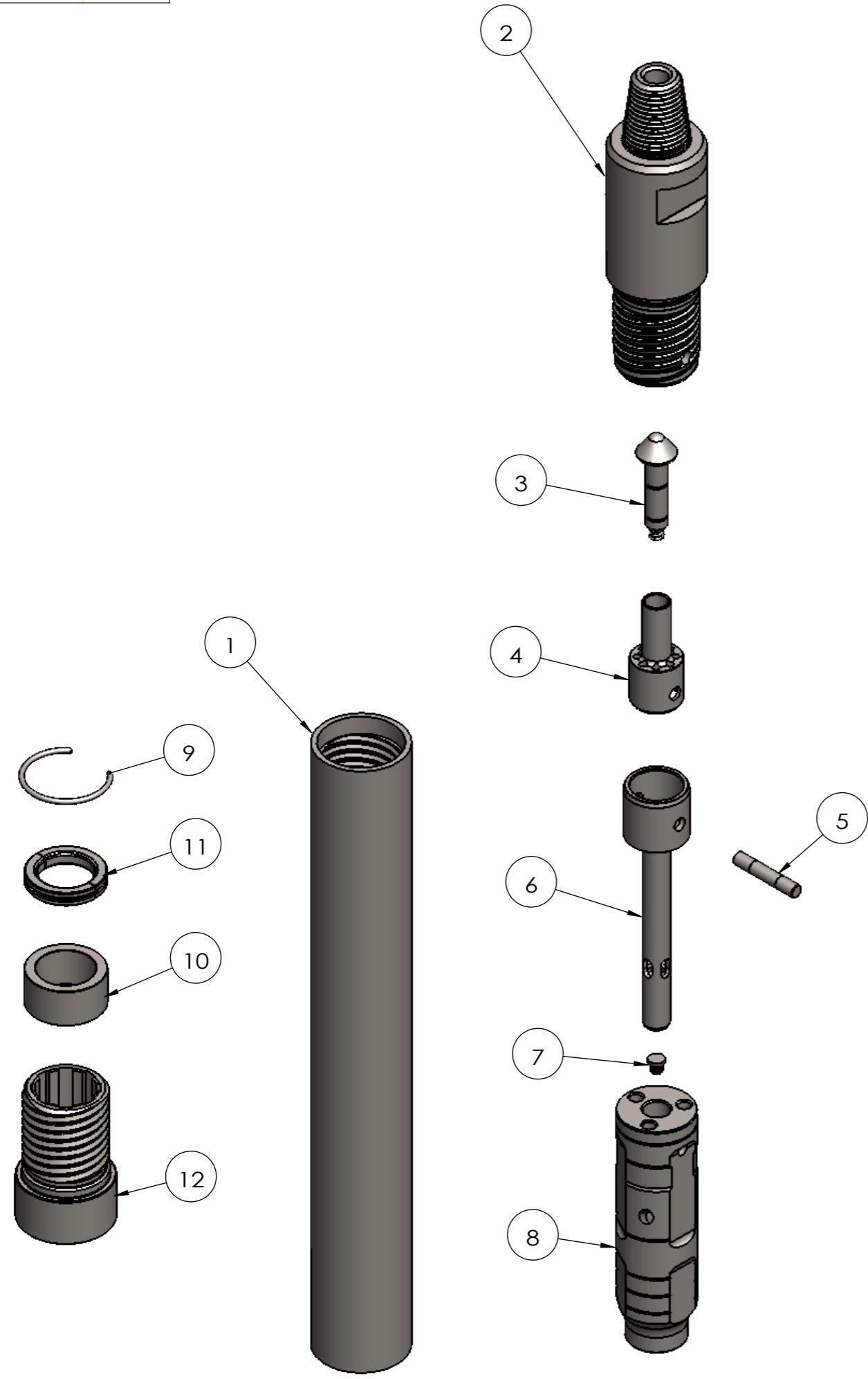

품번	품명	비고	수량
1	WEAR SLEEVE	CS-SP40MS-01	1
2	BACKHEAD	CS-SP40IR-02	1
3	CHECK VALVE with SPRING BUSH	Standard	1
4	CHECK VALVE BOX	CS-SP40IR-03	1
5	AIR TUBE PIN	CS-SP40IR-05	1
6	AIR TUBE	CS-SP40IR-04	1
7	PLUG BLIND	CS-SP40IR-06	1
8	PISTON	CS-SP40MS-07	1
9	PISTON STOP RING	Standard	1
10	GUIDE BUSH	CS-SP40MS-08	1
11	BIT RETAINING RING & O-RING	CS-SP40IR-09	1
12	CHUCK	CS-SP40MS-10	1

CS CHANG-SHIN INT'L CO.,LTD
ULSAN KOREA

APP'D		TITLE	Speedrill 40MS Hammer Assy
CH'D		MATERIAL	MODEL
CH'D		STANDARD	SP40MS
DRAW		Proj	32번
	DATE	SIGN.	Weight 38 kg DWG NO. CS-SP40MS-00

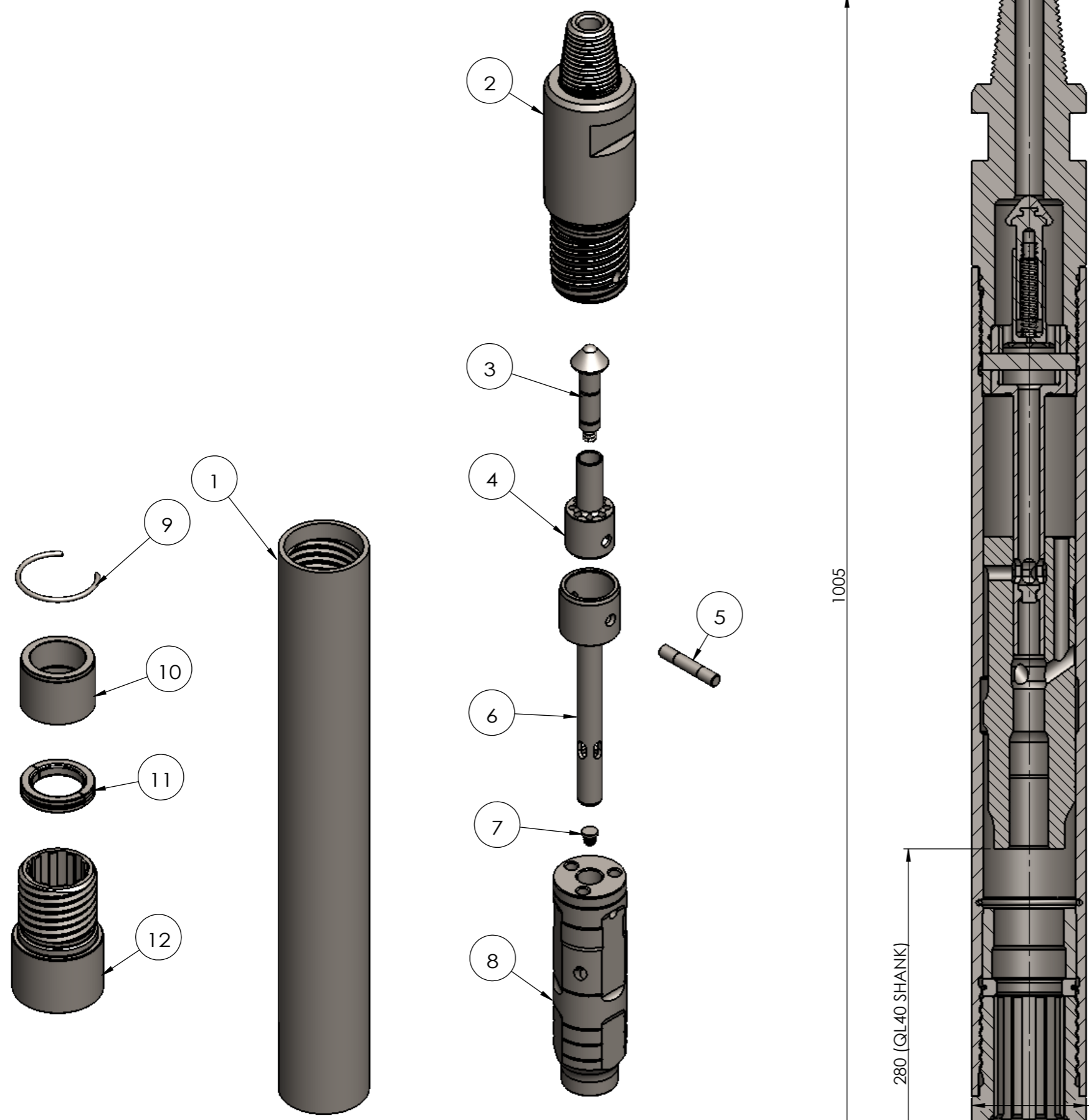

품번	품명	비고	수량
1	WEAR SLEEVE	CS-SP40MS-01	1
2	BACKHEAD	CS-SP40IR-02	1
3	CHECK VALVE with SPRING BUSH	Standard	1
4	CHECK VALVE BOX	CS-SP40IR-03	1
5	AIR TUBE PIN	CS-SP40IR-05	1
6	AIR TUBE	CS-SP40IR-04	1
7	PLUG BLIND	CS-SP40IR-06	1
8	PISTON	CS-SP40QL-07	1
9	PISTON STOP RING	Standard	1
10	GUIDE BUSH	CS-SP40QL-08	1
11	BIT RETAINING RING & O-RING	CS-SP40IR-09	1
12	CHUCK	CS-SP40QL-10	1

CHANG-SHIN INT'L CO.,LTD
ULSAN KOREA

APP'D		TITLE	
CH'D		Speedrill 40QL Hammer Assy	
CH'D		MATERIAL	MODEL
DRAW		STANDARD	SP40QL
DATE	SIGN.	Proj 3각법	DWG NO. CS-SP40QL-00
		Weight 38 kg	

REV.	DESCRIPTION	DATE	DWG	CH'D	CH'D	APP'D
△	First Issued	'17.09.18	CH.R.KIM	-	-	C.G.LEE

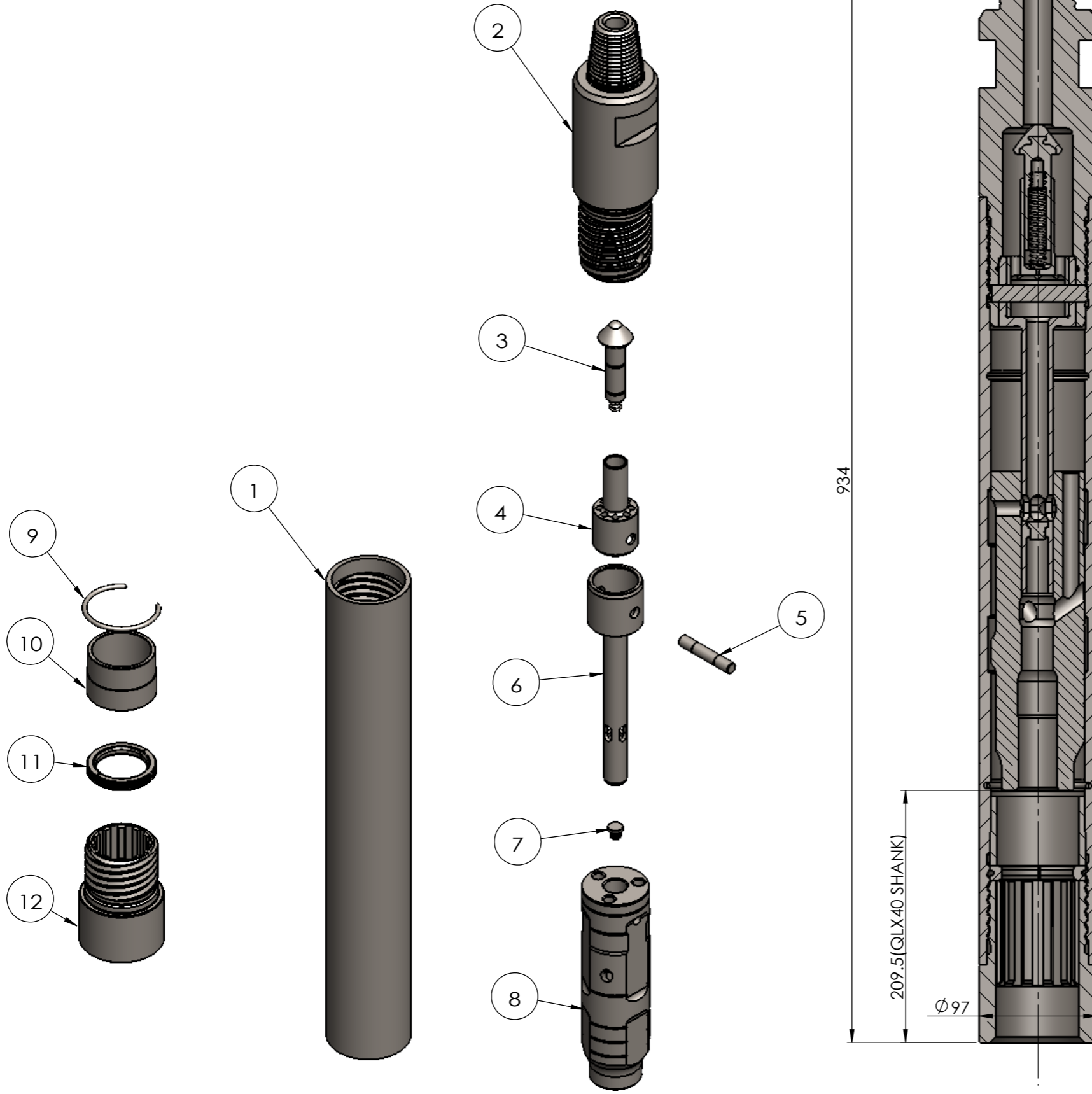

품번	품명	비고	수량
1	WEAR SLEEVE	CS-SP40IR-01	1
2	BACKHEAD	CS-SP40IR-02	1
3	CHECK VALVE with SPRING	Standard	1
4	CHECK VALVE BOX	CS-SP40IR-03	1
5	AIR TUBE PIN	CS-SP40IR-05	1
6	AIR TUBE	CS-SP40IR-04	1
7	PLUG BLIND	CS-SP40IR-06	1
8	PISTON	CS-SP40QL-07	1
9	PISTON STOP RING	Standard	1
10	GUIDE BUSH	CS-SP-QLX40-08	1
11	BIT RETAINING RING & O-RING	CS-SP-QLX40-09	1
12	CHUCK	CS-SP-QLX40-10	1

CS CHANG-SHIN INT'L CO.,LTD
ULSAN KOREA

APP'D		TITLE	Speedrill QLX40 Hammer Assy	
CH'D		MATERIAL	MODEL	
CH'D		STANDARD	SP QLX40	
DRAW		Proj	3각법	DWG NO.
DATE	SIGN.	Weight	34 kg	CS-SP-QLX40-00

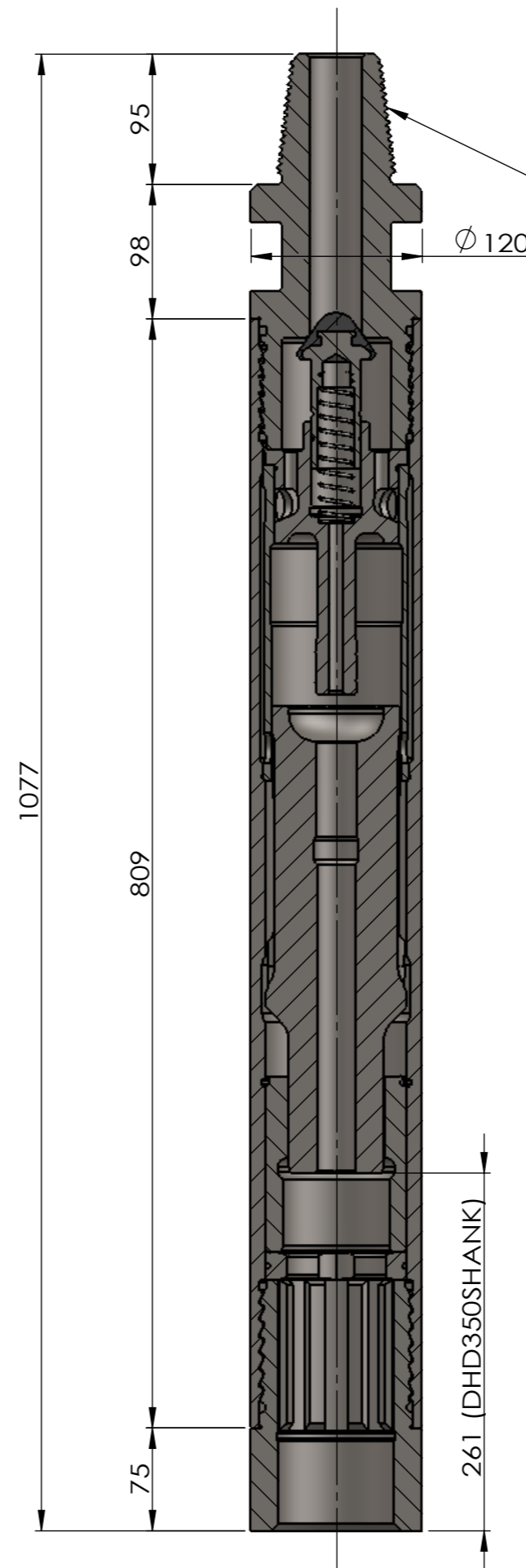
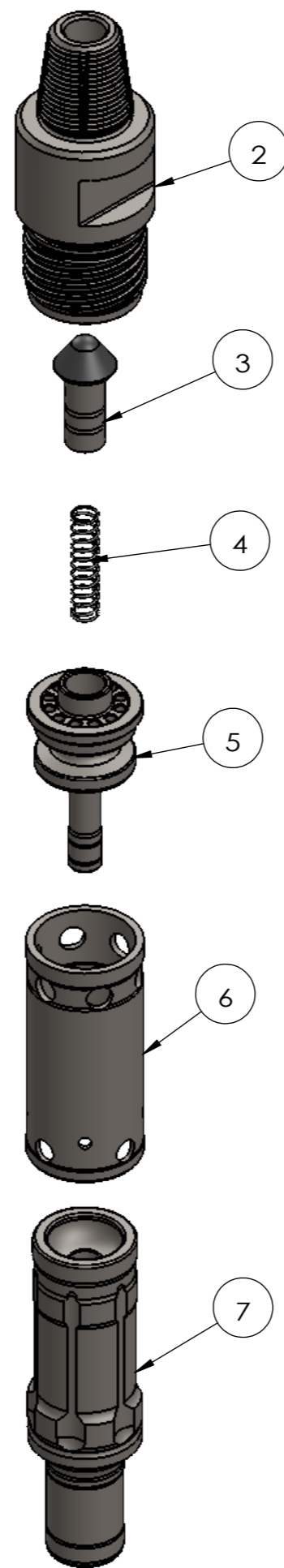
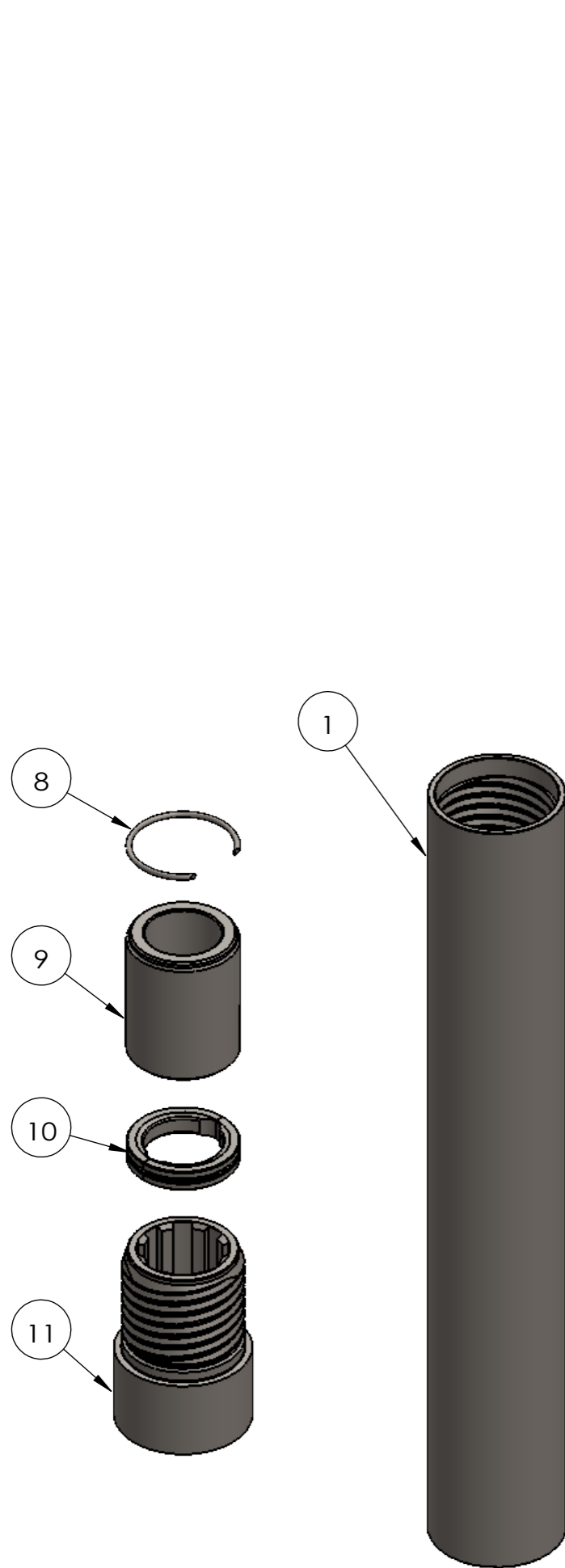

API 3-1/2" Reg Pin
인치 5산

품번	품명	비고	수량
1	Wearsleeve		1
2	BACKHEAD & O-RING		1
3	CHECK VALVE	6" 공용	1
4	CHECK VALVE SPRING	6" 공용	1
5	AIR DISTRIBUTER		1
6	CYLINDER		1
7	PISTON		1
8	Piston Stop Ring		1
9	Piston Bush		1
10	Bit ring		1
11	Chuck		1



APP'D		TITLE	NEO 50 Hammer Assy	
CH'D		MATERIAL	Model	
CH'D		STANDARD	5" Neo Drill	
DRAW		Proj	3각법	DWG NO.
	DATE	SIGN.	Weight 68 kg	CS-NEO-50-IR-00

REV.	DESCRIPTION	DATE	DWG	CH'D	CH'D	APP'D
△	First Issued	'17.09.05	CH.R.KIM	-	-	C.G.LEE

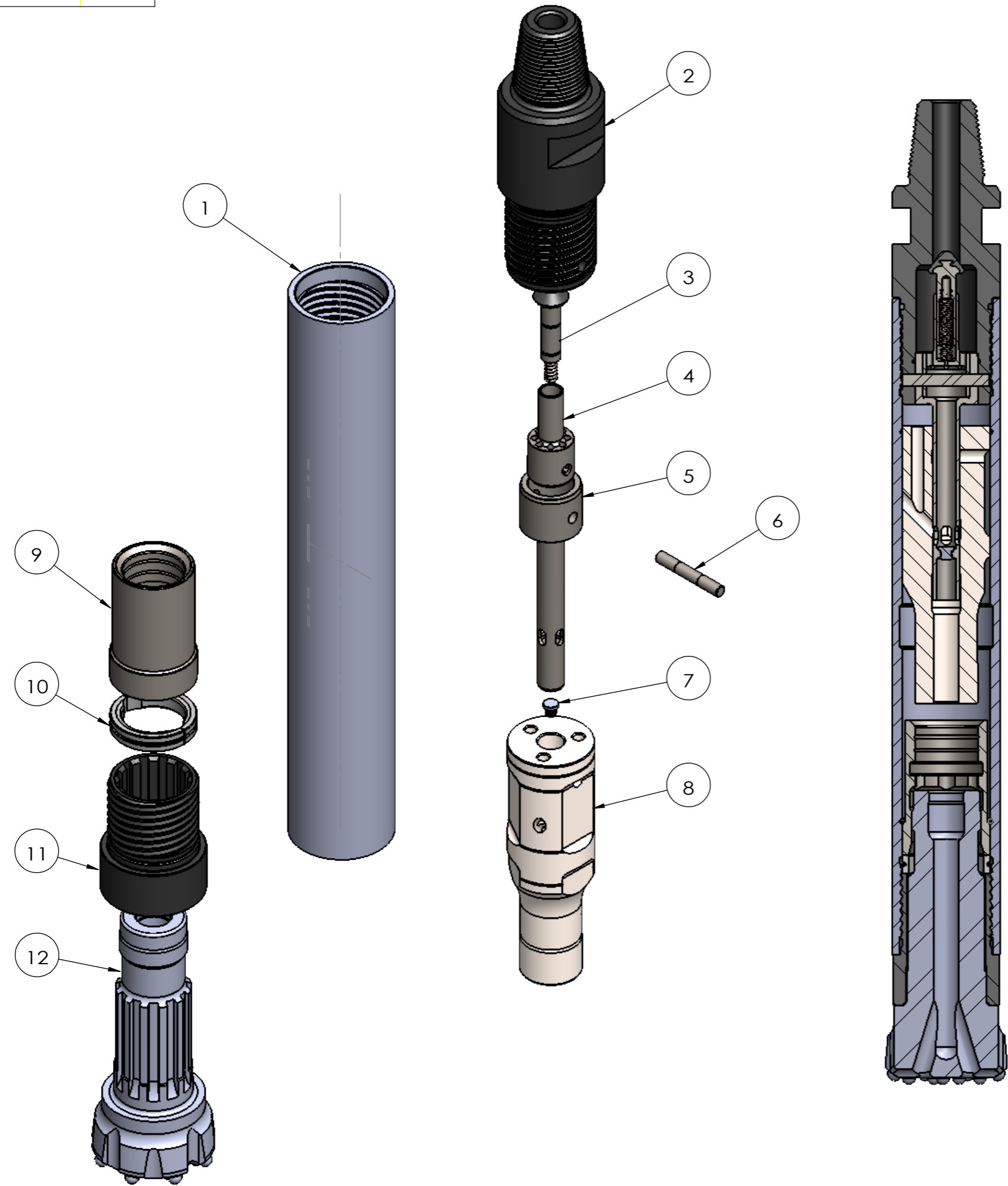

품번	품명	수량
1	WEAR SLEEVE	1
2	BACKHEAD	1
3	CHECK VALVE WITH SPRING	1
4	CHECK VALVE BOX	1
5	AIR TUBE	1
6	AIR TUBE PIN	1
7	PLUG-BLIND	1
8	PISTON	1
9	PISTON BUSH	1
10	BIT RETAINING RING & O-ring	1
11	CHUCK	1
12	Bit	1

CS CHANG-SHIN INT'L CO.,LTD
ULSAN KOREA

APP'D		TITLE	Sp 50QL_VL Hammer Assy	
CH'D		MATERIAL	MODEL	
CH'D		STANDARD	SP50QL/VL	
DRAW		Proj	3각법	DWG NO.
DATE	SIGN.	Weight	56.2 kg	SP50QL-VL-00

REV.	DESCRIPTION	DATE	DWG	CH'D	CH'D	APP'D
△	First Issued	'17.08.17	J.Y.CHO	CH.R.KIM	-	C.G.LEE

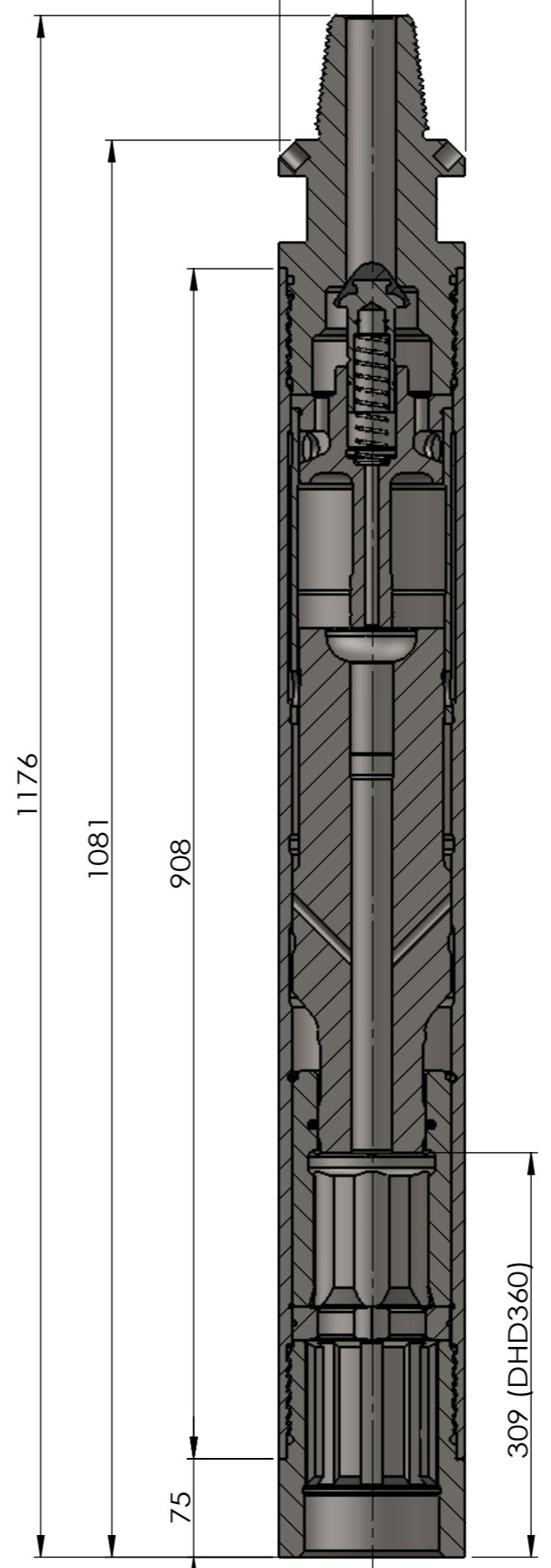
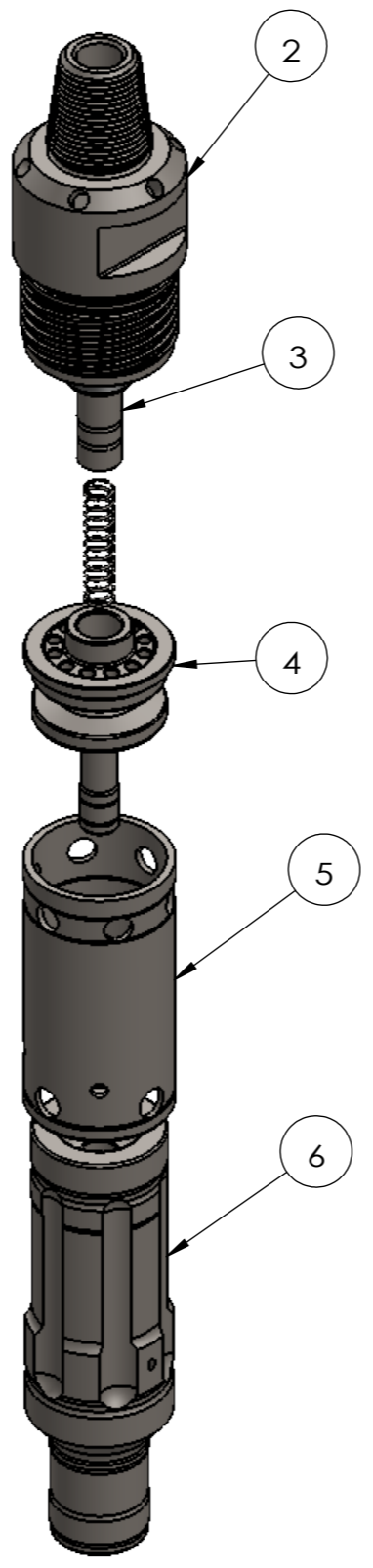
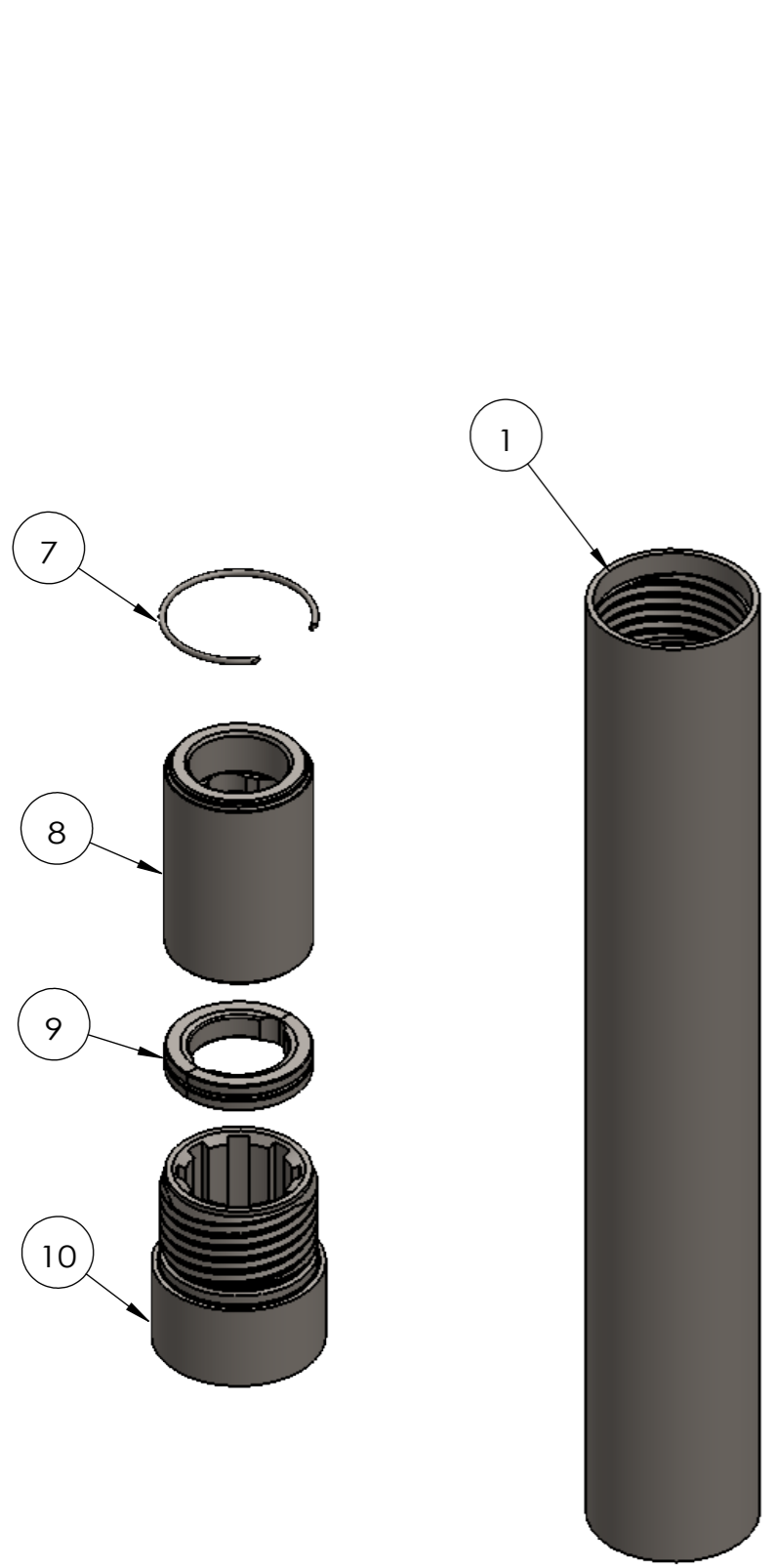

품번	품명	수량
1	Wearsleeve	1
2	BACKHEAD & O-RING	1
3	CHECK VALVE & SPRING	1
4	AIR DISTRIBUTER	1
5	CYLINDER	1
6	PISTON	1
7	PISTON STOP RING	1
8	PISTON BUSH	1
9	BIT RING	1
10	CHUCK	1

CS CHANG-SHIN INT'L CO.,LTD
ULSAN KOREA

APP'D		TITLE	NMG_6인치 Hammer Assy	
CH'D		MATERIAL	Model	
CH'D		Standard	NMG_6" Hammer	
DRAW		Proj	3각법	DWG NO.
DATE	SIGN.	Weight	- kg	CS-NMG-60-IR-00

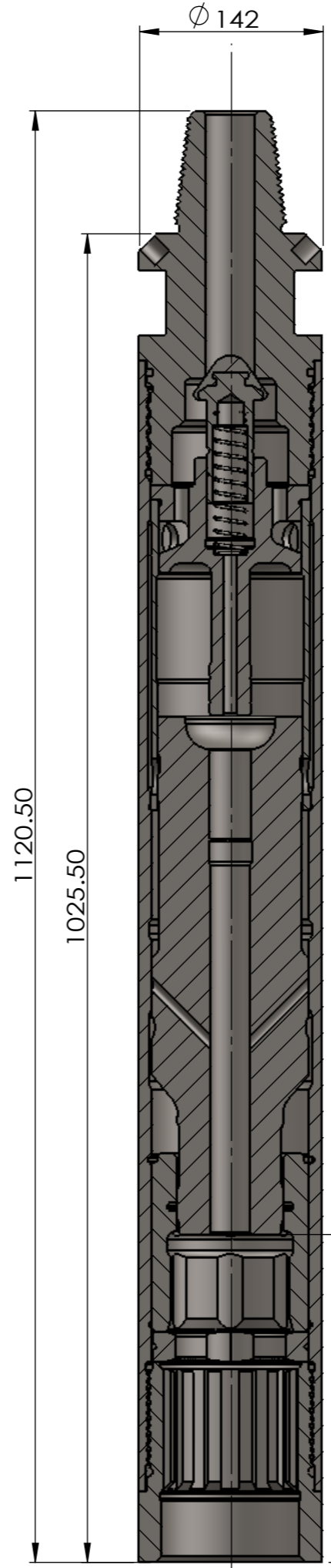
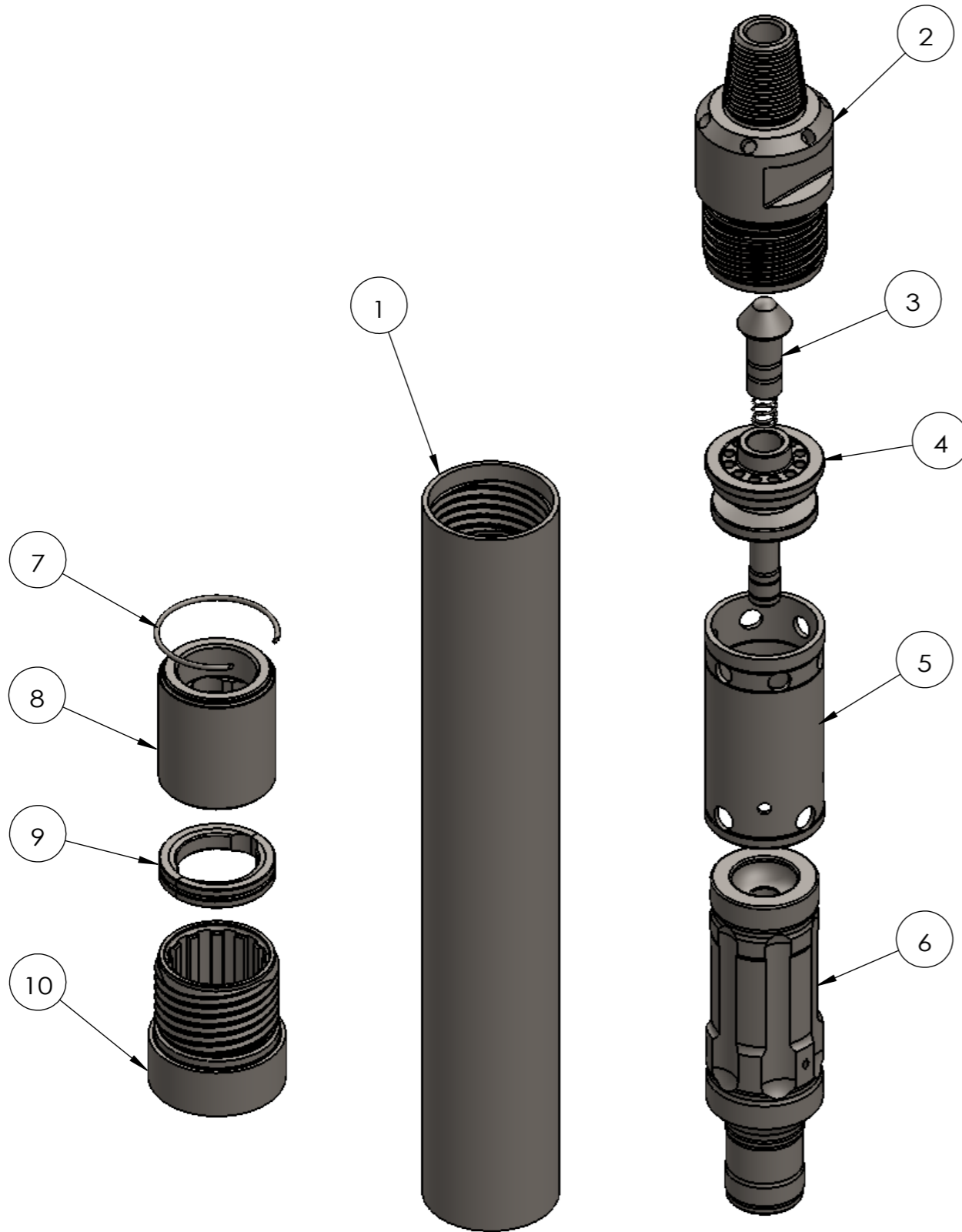

품번	품명	수량
1	Wearsleeve QL	1
2	BACKHEAD & O-RING	1
3	CHECK VALVE & SPRING	1
4	AIR DISTRIBUTER	1
5	CYLINDER	1
6	PISTON	1
7	PISTON STOP RING	1
8	Piston Bush QL	1
9	Bit ring QL	1
10	Chuck QL	1

CS CHANG-SHIN INT'L CO.,LTD
ULSAN KOREA

APP'D		TITLE	NMG_6인치 QL Hammer Assy	
CH'D		MATERIAL	Model	
CH'D		Standard	NMG_6" Hammer	
DRAW		Proj	3각법	DWG NO.
DATE	SIGN.	Weight	90 kg	CS-NMG-60-QL-00

REV.	DESCRIPTION	DATE	DWG	CH'D	CH'D	APP'D
△	First Issued	'17.08.17	J.Y.CHO	CH.R.KIM	-	C.G.LEE
△	피스톤 모델링 표기 수정	'17.09.29	J.Y.CHO	CH.R.KIM	-	C.G.LEE

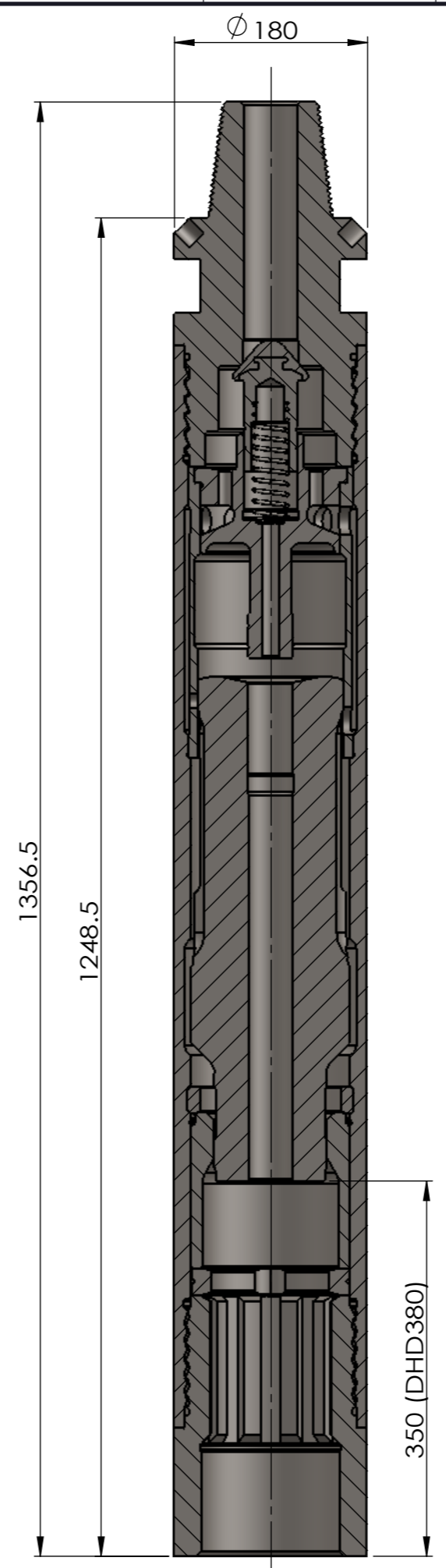
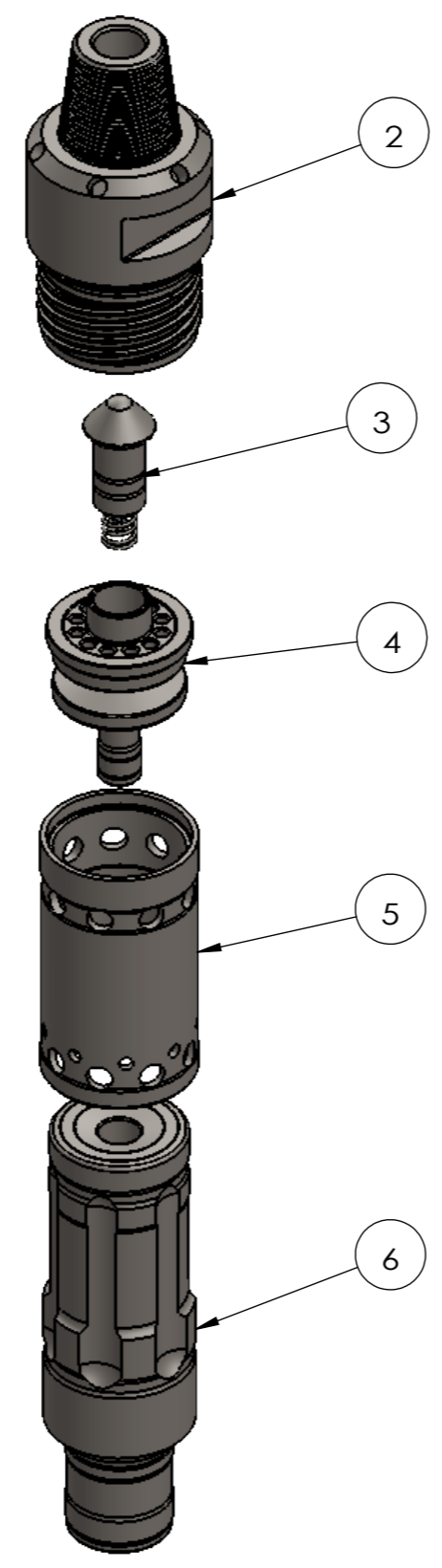
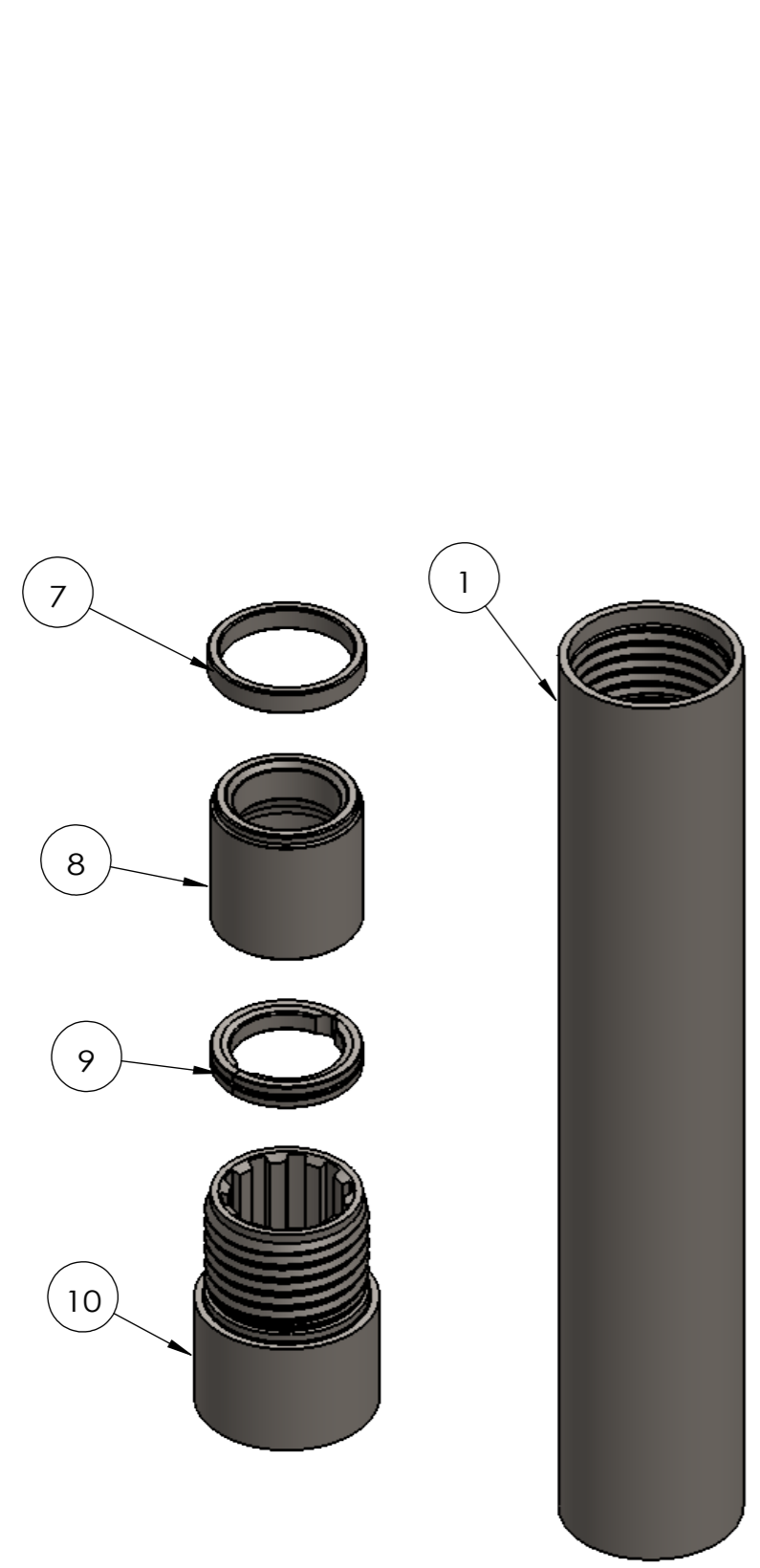

품번	품명	수량
1	Wearsleeve	1
2	BACKHEAD & O-RING	1
3	CHECK VALVE with SPRING	1
4	AIR DISTRIBUTER	1
5	CYLINDER	1
6	PISTON	1
7	PISTON STOP RING	1
8	PISTON BUSH	1
9	BIT RING	1
10	CHUCK	1

		CHANG-SHIN INT'L CO.,LTD ULSAN KOREA	
		TITLE: NMG_8인치 Hammer	
APP'D		MATERIAL: Standard	
CH'D		Model: NMG 8인치	
CH'D		Standard	
DRAW		Proj: 3각법	DWG NO. CS-NMG-80-IR-00
DATE	SIGN.	Weight: 232 kg	

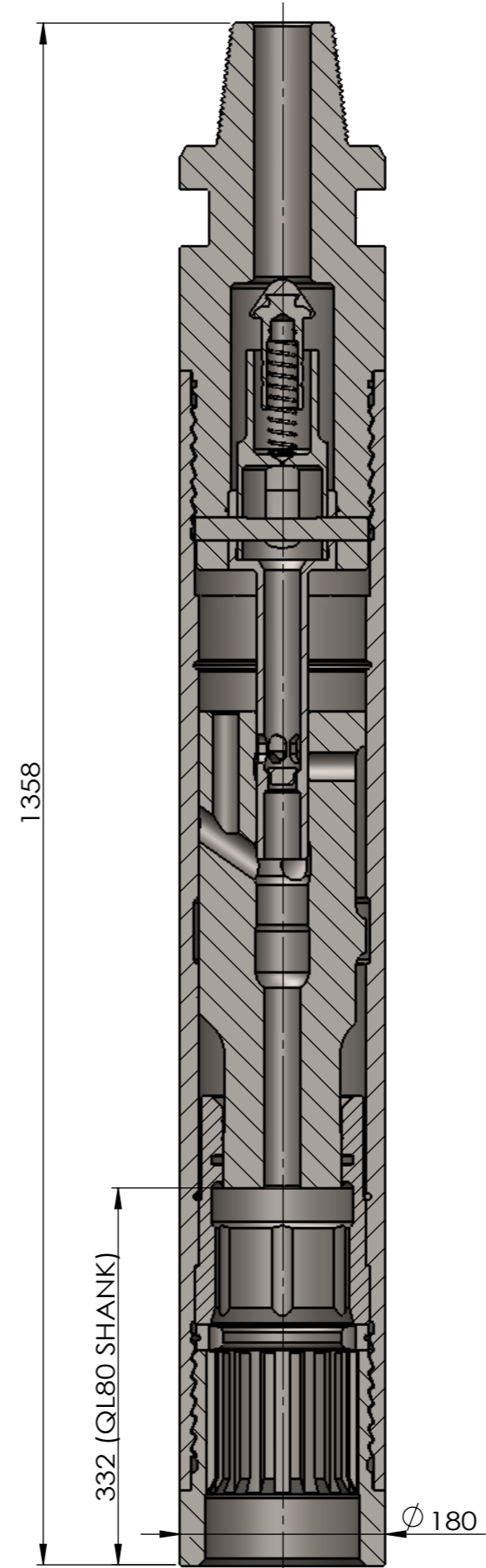
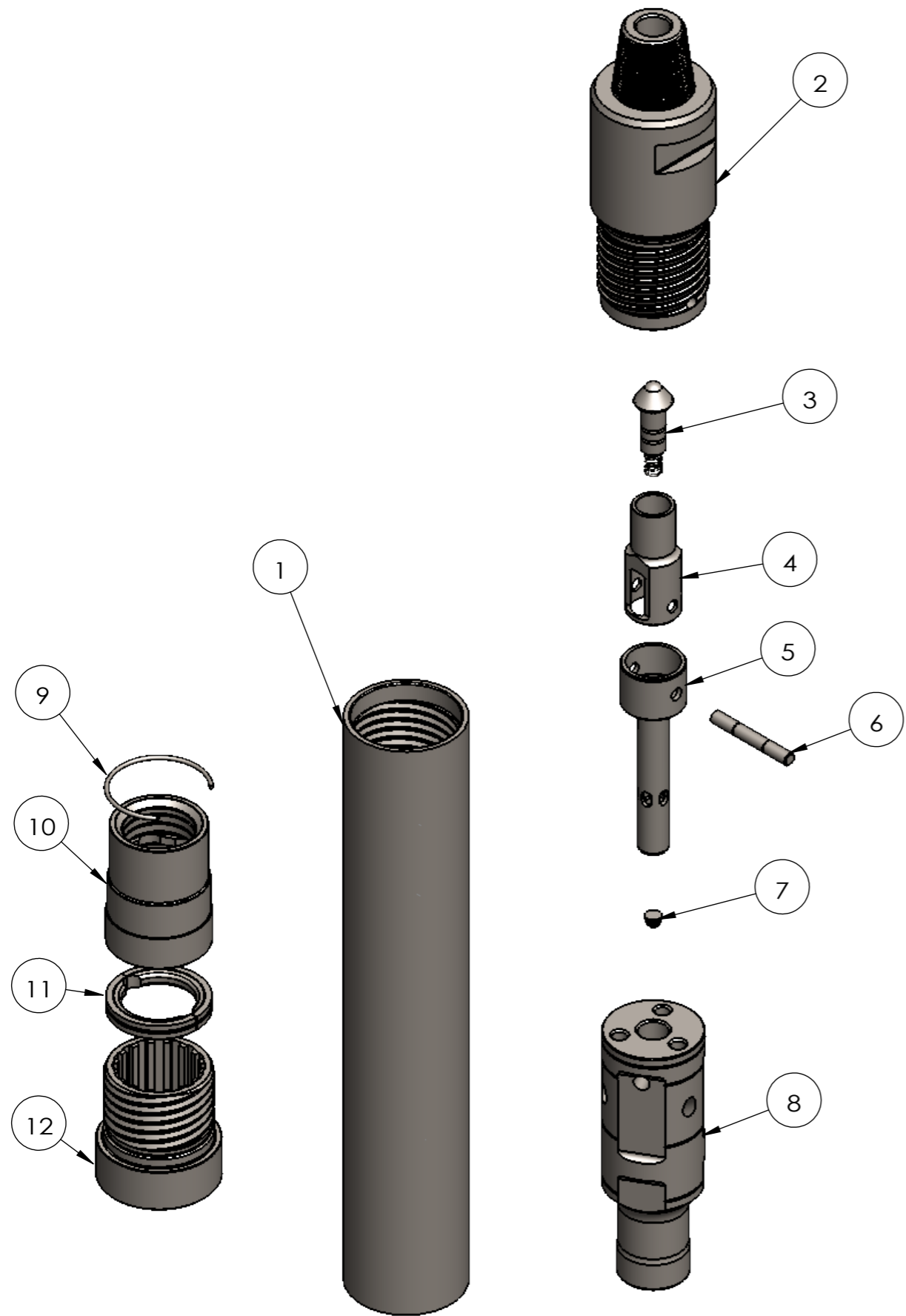

품번	품명	비고	수량
1	WEAR SLEEVE	CS-Sp80IR-V2-01	1
2	BACKHEAD & O-RING	CS-Sp80IR-V2-02	1
3	CHECK VALVE with SPRING	STANDARD	1
4	CHECK VALVE BOX	CS-Sp80IR-V2-03	1
5	AIR TUBE	Sp80IR-VL-V2-04	1
6	AIR TUBE PIN	CS-Sp80IR-V2-05	1
7	PLUG-BLIND	CS-Sp80IR-06	1
8	PISTON	CS-Sp60IR-07	1
9	PISTON STOP RING	STANDARD	1
10	PISTON BUSH	Sp80QL-VL-V2-08	1
11	BIT RING & O-RING	CS-Sp80QL-09	1
12	CHUCK	CS-Sp80IR-10	1

CHANG-SHIN INT'L CO.,LTD
ULSAN KOREA

APP'D		TITLE	SP80QL VL Hammer Assy Version 2	
CH'D		MATERIAL	MODEL	
CH'D		Standard	VL / VERSION 2	
DRAW		Proj	3각법	DWG NO.
	DATE	SIGN.	Weight 177 kg	SP80QL-VL-V2-00