

REV.	DESCRIPTION	DATE	DWG	CH'D	CH'D	APP'D
△	First Issued	'19.02.08	CH.R.KIM	-	-	C.G.LEE

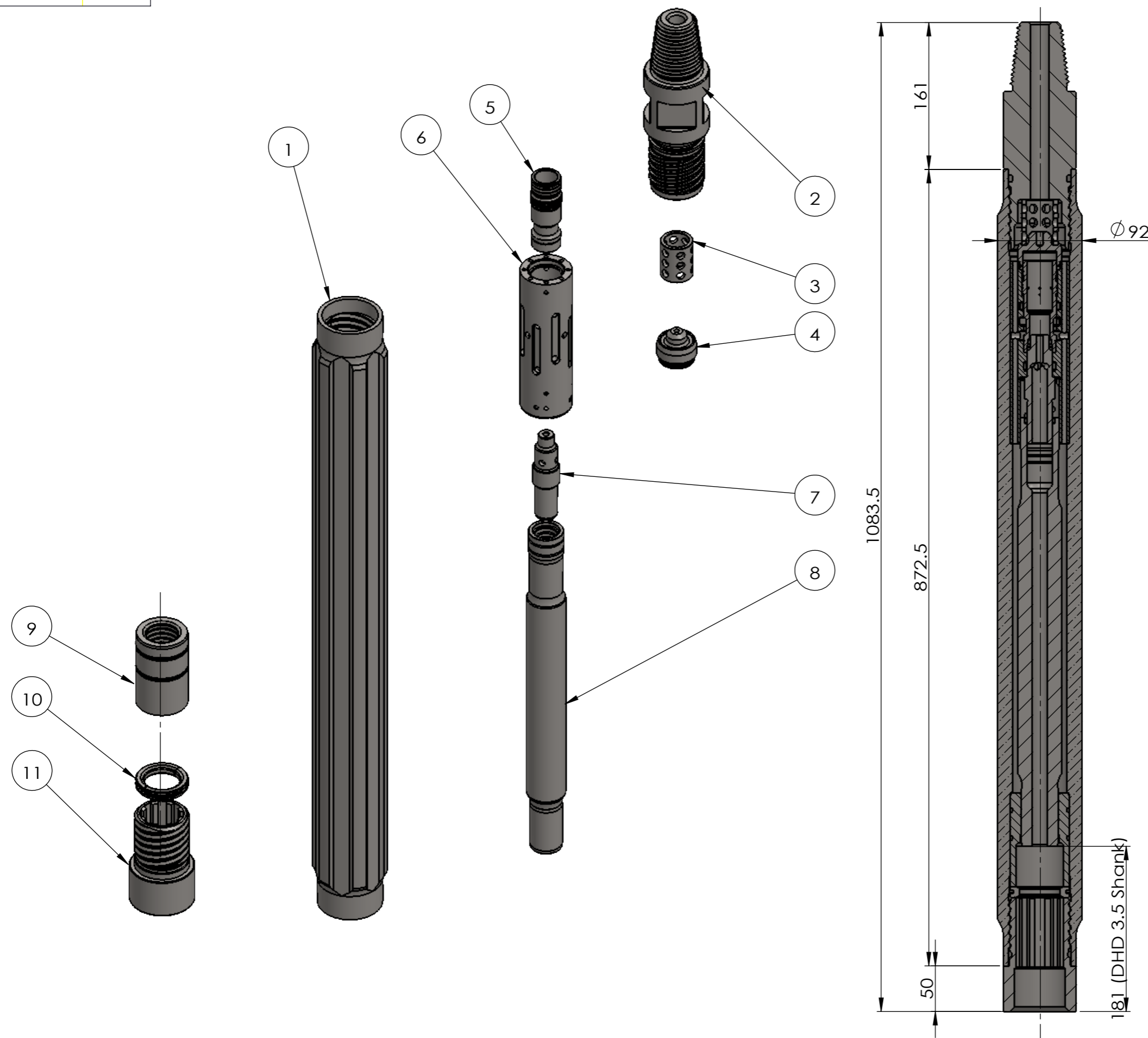

품번	품명	수량
1	WEAR SLEEVE_W30_V4.0	1
2	BACKHEAD_W30_V4.0	1
3	Filter Ring_W30_V4.0	1
4	Valve Cover_W30_V4.0	1
5	Valve_W30_V4.0	1
6	Valve Housing_W30_V4.0	1
7	Sliding Tube_W30_V4.0	1
8	Piston_W30_V4.0	1
9	PISTON BUSH_W30_V3.0	1
10	BIT RING_W30_V3.0	1
11	CHUCK_W30_V3.0	1

CS CHANG-SHIN INT'L CO.,LTD
ULSAN KOREA

APP'D		TITLE	Water Powered DTH Hammer
CH'D		MATERIAL	STD
CH'D		MODEL	W30_V4.0
DRAW		Proj	3각법
DATE	SIGN.	Weight	34 kg
		DWG NO.	CS-W30-H

REV.	DESCRIPTION	DATE	DWG	CH'D	CH'D	APP'D
△	First Issued	'19.02.08	CH.R.KIM	-	-	C.G.LEE

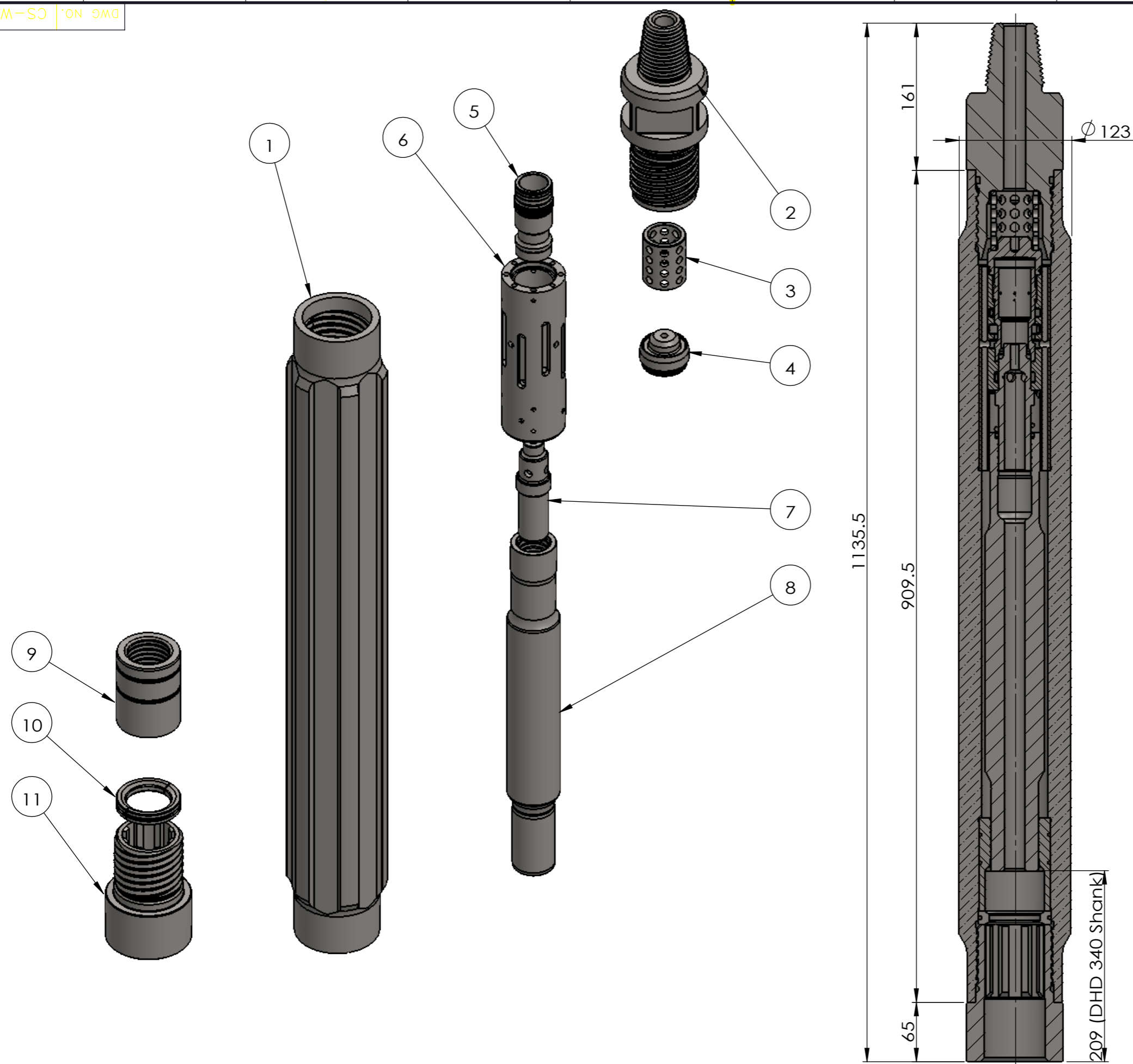

품번	품명	수량
1	WEAR SLEEVE_W40_V3.1	1
2	BACKHEAD_W40_V3.1	1
3	Filter Ring_W40_V4.0	1
4	Valve Cover_W40_V4.0	1
5	Valve_W40_V4.0	1
6	Valve Housing_W40_V4.0	1
7	Sliding Tube_W40_V4.0	1
8	Piston_W40_V4.0	1
9	PISTON BUSH_W40_V4.0	1
10	BIT RETAINING RING & O-ring	1
11	Chuck W40_V4.0	1

CS CHANG-SHIN INT'L CO.,LTD
ULSAN KOREA

APP'D		TITLE	Water Powered DTH Hammer
CH'D		MATERIAL	STD
CH'D		MODEL	W40_V4.0
DRAW		Proj	3각법
DATE	SIGN.	Weight	64 kg
		DWG NO.	CS-W40-H

REV.	DESCRIPTION	DATE	DWG	CH'D	CH'D	APP'D
△	First Issued	'19.02.16	CH.R.KIM	-	-	C.G.LEE
△	코팅 및 스트로크 최신화	'19.12.12	J.Y.CHO	-	-	C.G.LEE

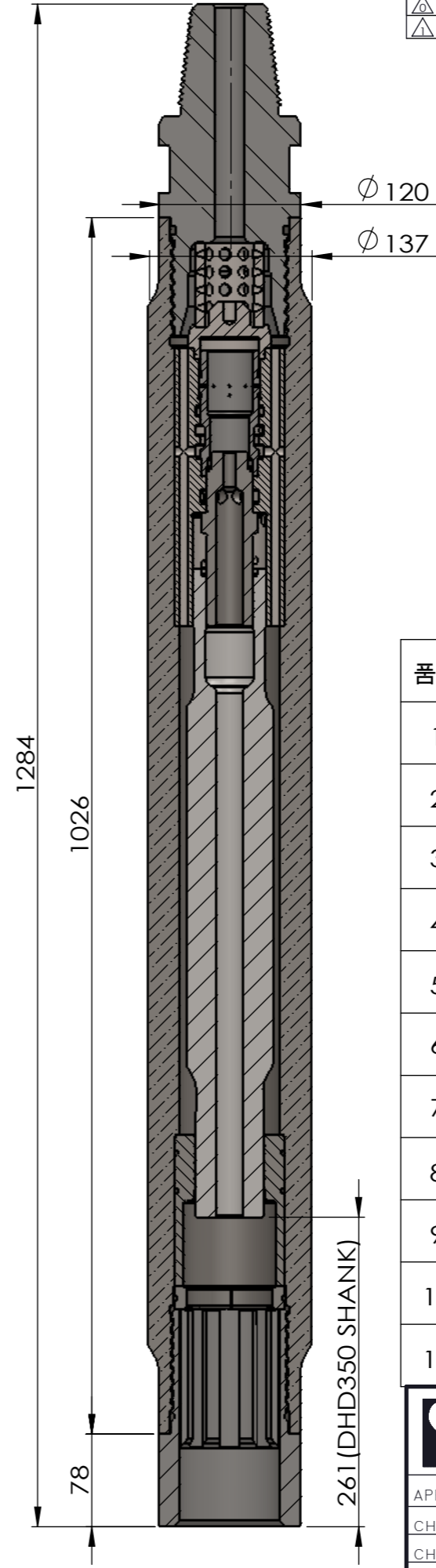
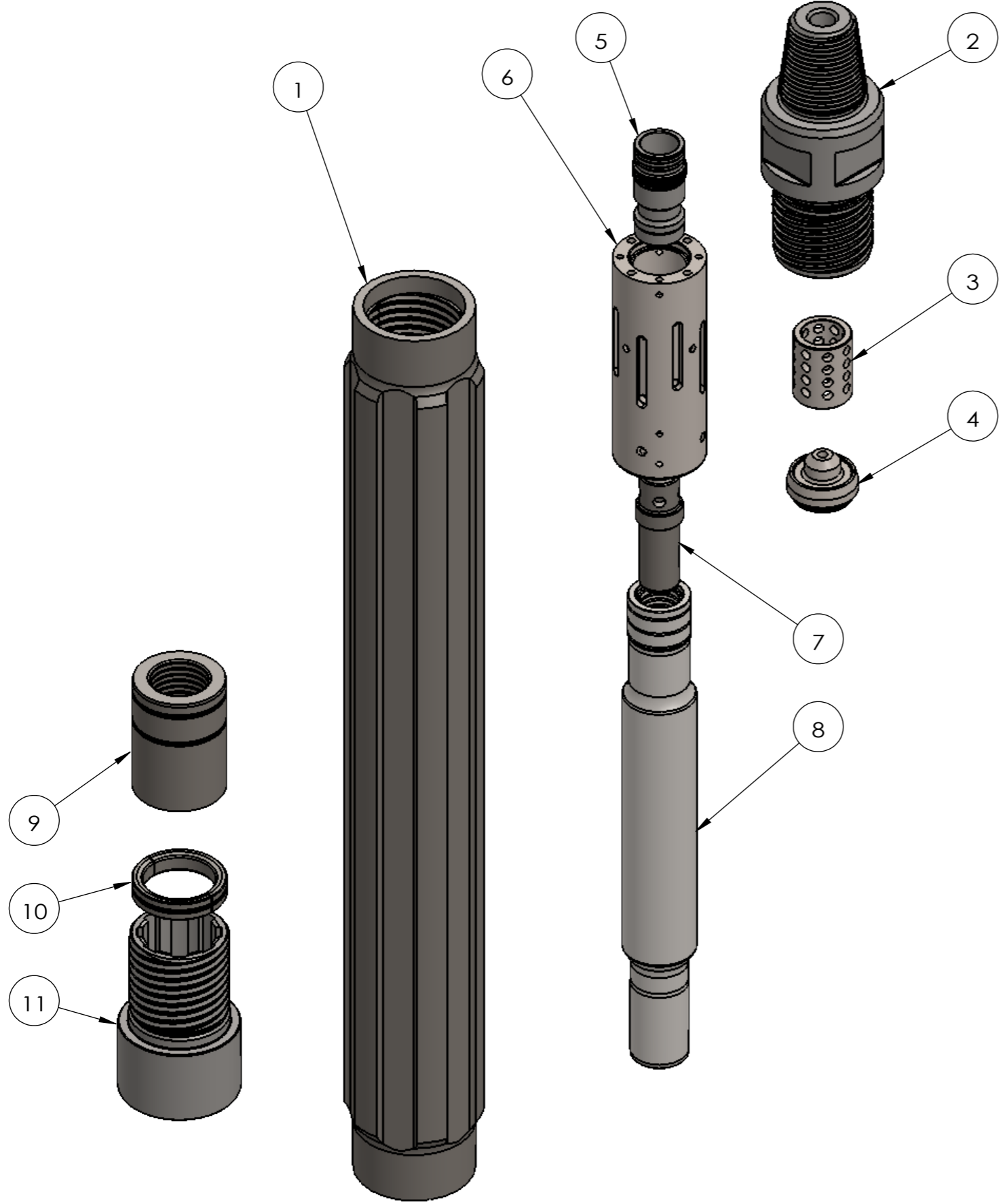

품번	품명	수량
1	WEAR SLEEVE_W50	1
2	BACKHEAD_W50	1
3	Filter Ring	1
4	Valve Cover_W50	1
5	Valve_W50	1
6	Valve Housing_W50	1
7	Sliding Tube_W50	1
8	Piston_W50	1
9	PISTON BUSH_W50	1
10	BIT RING_W50	1
11	CHUCK_W50	1

CS CHANG-SHIN INT'L CO.,LTD
ULSAN KOREA

APP'D		TITLE	Water Powered DTH Hammer
CH'D		MATERIAL	STD
CH'D		MODEL	W50_V4.0
DRAW		Proj	3각법
DATE	SIGN.	Weight	94 kg
		DWG NO.	CS-W50-H

REV.	DESCRIPTION	DATE	DWG	CH'D	CH'D	APP'D
△	First Issued	'19.02.08	CH.R.KIM	-	-	C.G.LEE

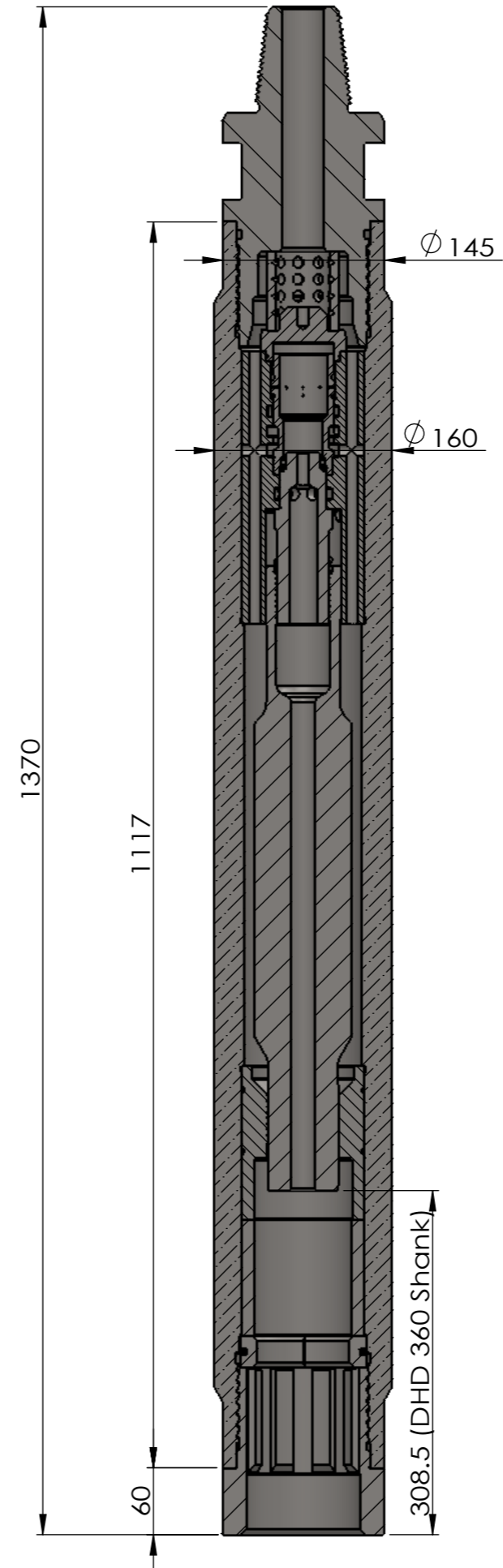
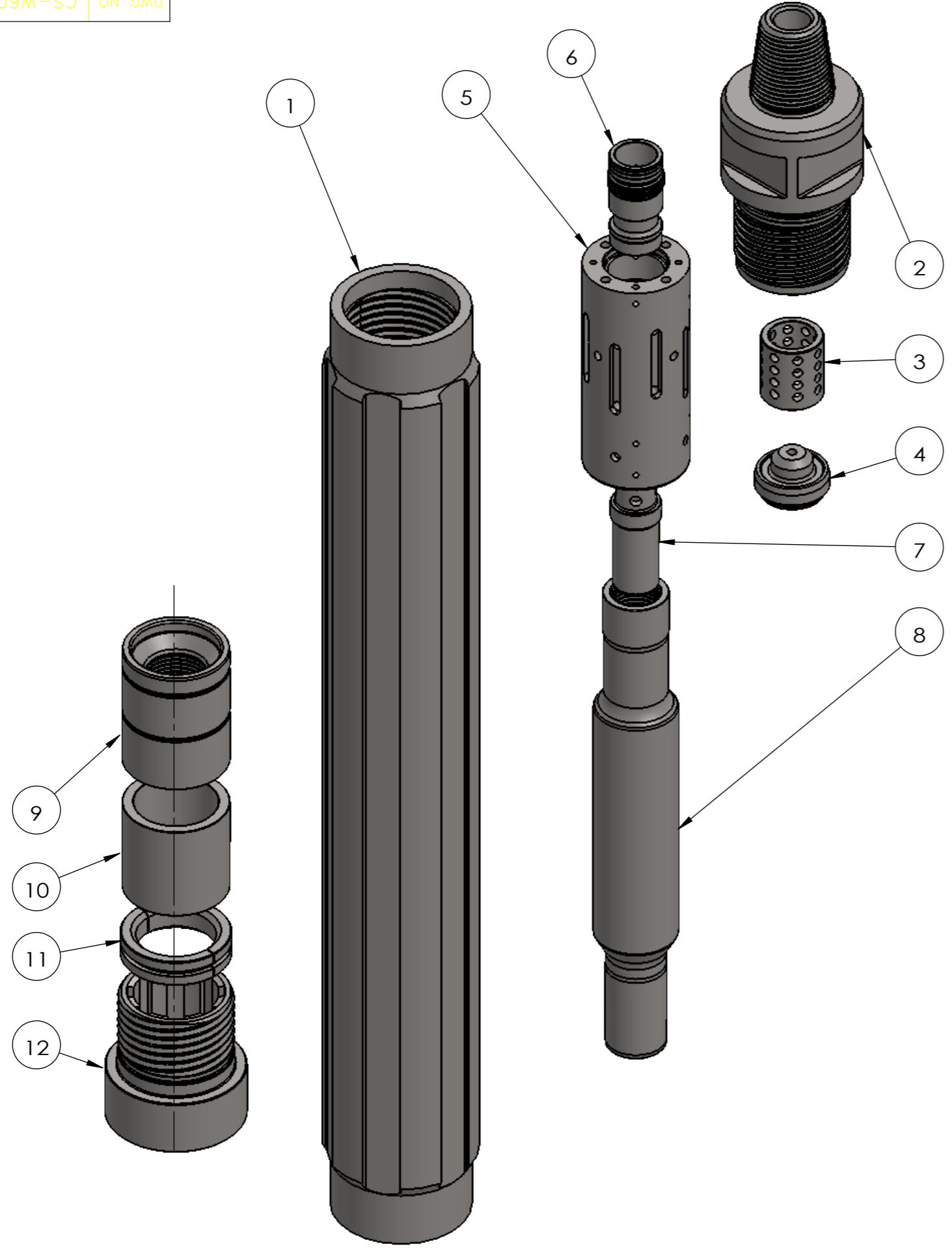

품번	품명	수량
1	WEAR SLEEVE	1
2	BACKHEAD & O-RING	1
3	Filter Ring	1
4	Valve Cover_W60_V4.0	1
5	Valve Housing_W60_V4.0	1
6	Valve_W60_V4.0	1
7	Sliding Tube_W60_V4.0	1
8	Piston_W60_V4.0	1
9	Piston Bush	1
10	Distance Ring_W60_V3.0	1
11	BIT RING	1
12	CHUCK	1

CS CHANG-SHIN INT'L CO.,LTD
ULSAN KOREA

APP'D		TITLE	Water Powered DTH Hammer
CH'D		MATERIAL	STD
CH'D		MODEL	W60_V4.0
DRAW		Proj	3각법
DATE	SIGN.	Weight	140 kg
		DWG NO.	CS-W60-H

REV.	DESCRIPTION	DATE	DWG	CH'D	CH'D	APP'D
△	First Issued	'17.05.31	J.Y.CHO	CH.R.KIM		C.G.LEE

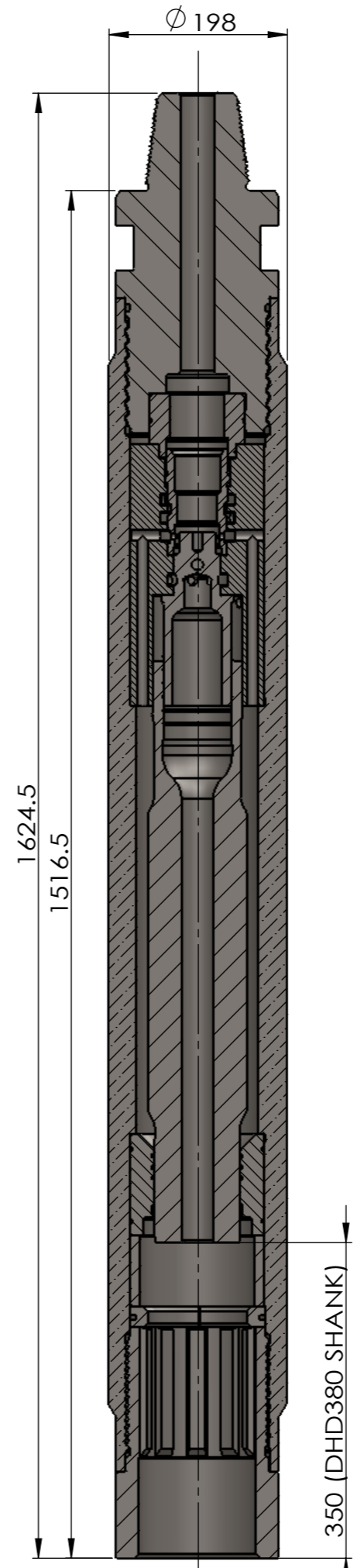
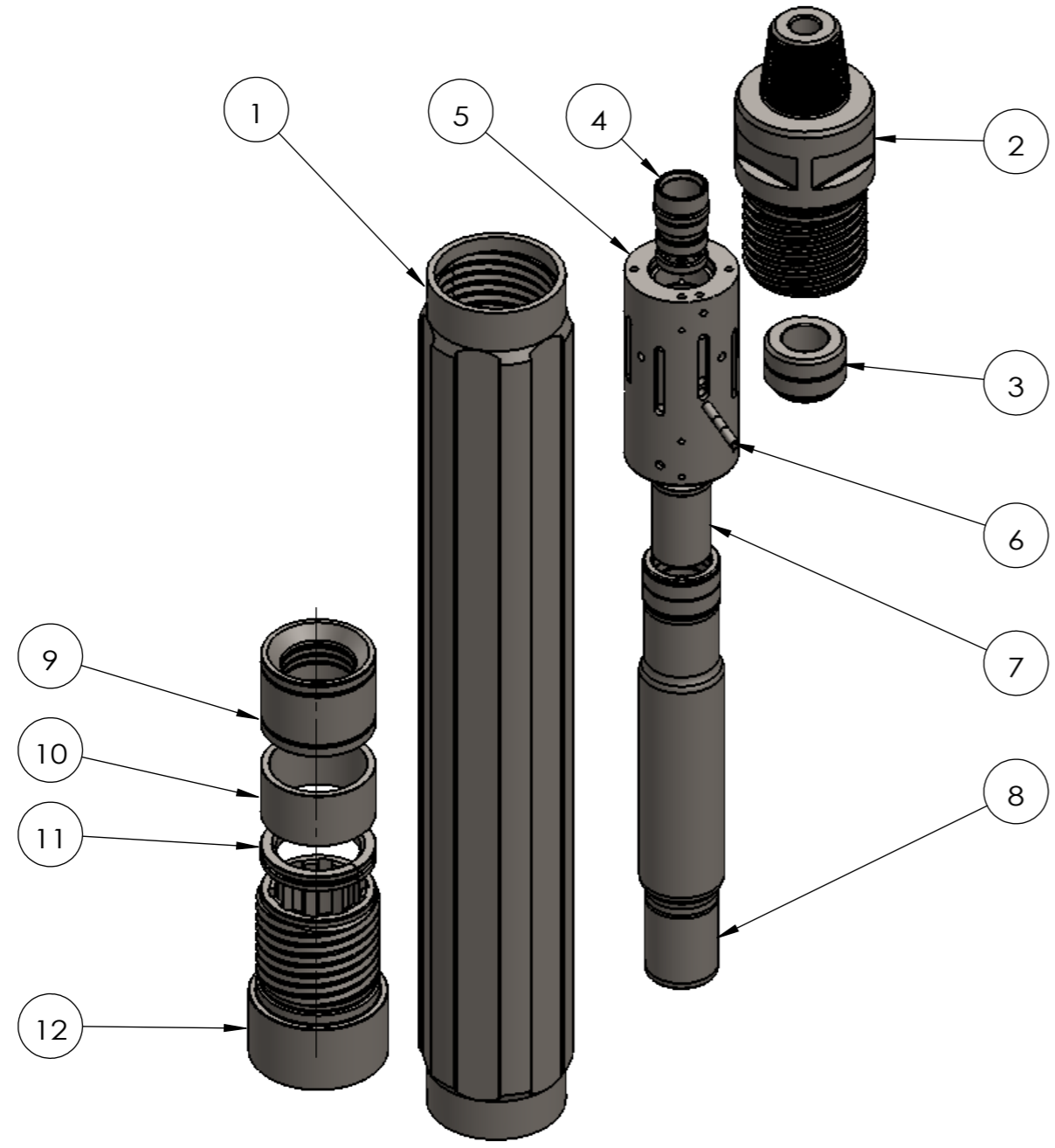

품번	품명	수량
1	WEAR SLEEVE	1
2	BACKHEAD & O-RING	1
3	Valve Cover_W80	1
4	Valve_W80	1
5	Valve Housing_W80	1
6	Pin_W80	1
7	Sliding Tube_W80	1
8	Piston_W80	1
9	Piston Bush_W80	1
10	Distance Ring_W80	1
11	BIT RING_W80	1
12	CHUCK_W80	1

CS CHANG-SHIN INT'L CO.,LTD
ULSAN KOREA

APP'D		TITLE	Water Powered DTH Hammer
CH'D		MATERIAL	STD
CH'D		MODEL	W80_V3.1
DRAW		Proj	3각법
DATE	SIGN.	Weight	226 kg
		DWG NO.	CS-W80-H